







	<p><b>SCHLOSSERHAMMER</b> Eschenstiel, lackiert</p> <table border="0"> <tr> <td>100g</td> <td>Bestell- Nr.:</td> <td>A. 750- 01</td> <td><b>1,90</b></td> </tr> <tr> <td>200g</td> <td></td> <td>A. 750- 02</td> <td><b>2,30</b></td> </tr> <tr> <td>300g</td> <td></td> <td>A. 750- 03</td> <td><b>2,80</b></td> </tr> <tr> <td>500g</td> <td></td> <td>A. 750- 05</td> <td><b>3,80</b></td> </tr> <tr> <td>800g</td> <td></td> <td>A. 750- 07</td> <td><b>5,10</b></td> </tr> <tr> <td>1000g</td> <td></td> <td>A. 750- 08</td> <td><b>6,00</b></td> </tr> </table>	100g	Bestell- Nr.:	A. 750- 01	<b>1,90</b>	200g		A. 750- 02	<b>2,30</b>	300g		A. 750- 03	<b>2,80</b>	500g		A. 750- 05	<b>3,80</b>	800g		A. 750- 07	<b>5,10</b>	1000g		A. 750- 08	<b>6,00</b>	<p>Preis in € ohne MWst</p>																
100g	Bestell- Nr.:	A. 750- 01	<b>1,90</b>																																							
200g		A. 750- 02	<b>2,30</b>																																							
300g		A. 750- 03	<b>2,80</b>																																							
500g		A. 750- 05	<b>3,80</b>																																							
800g		A. 750- 07	<b>5,10</b>																																							
1000g		A. 750- 08	<b>6,00</b>																																							
	<p><b>SCHLOSSERHAMMER</b> Fiberglasstiel</p> <table border="0"> <tr> <td>200g</td> <td>Bestell- Nr.:</td> <td>B. 3850</td> <td><b>1,50</b></td> </tr> <tr> <td>300g</td> <td></td> <td>B. 3852</td> <td><b>2,00</b></td> </tr> <tr> <td>500g</td> <td></td> <td>B. 3854</td> <td><b>2,90</b></td> </tr> <tr> <td>800g</td> <td></td> <td>B. 3855</td> <td><b>3,80</b></td> </tr> </table>	200g	Bestell- Nr.:	B. 3850	<b>1,50</b>	300g		B. 3852	<b>2,00</b>	500g		B. 3854	<b>2,90</b>	800g		B. 3855	<b>3,80</b>																									
200g	Bestell- Nr.:	B. 3850	<b>1,50</b>																																							
300g		B. 3852	<b>2,00</b>																																							
500g		B. 3854	<b>2,90</b>																																							
800g		B. 3855	<b>3,80</b>																																							
	<p><b>GUMMIHAMMER</b> Eschenstiel, poliert</p> <table border="0"> <tr> <td>90 x 50 mm</td> <td>Bestell- Nr.:</td> <td>A. 747- 1</td> <td><b>3,90</b></td> </tr> <tr> <td>110 x 60 mm</td> <td></td> <td>A. 747- 2</td> <td><b>5,20</b></td> </tr> <tr> <td>120 x 70 mm</td> <td></td> <td>A. 747- 3</td> <td><b>7,50</b></td> </tr> <tr> <td>130 x 80 mm</td> <td></td> <td>A. 747- 4</td> <td><b>12,00</b></td> </tr> </table>	90 x 50 mm	Bestell- Nr.:	A. 747- 1	<b>3,90</b>	110 x 60 mm		A. 747- 2	<b>5,20</b>	120 x 70 mm		A. 747- 3	<b>7,50</b>	130 x 80 mm		A. 747- 4	<b>12,00</b>																									
90 x 50 mm	Bestell- Nr.:	A. 747- 1	<b>3,90</b>																																							
110 x 60 mm		A. 747- 2	<b>5,20</b>																																							
120 x 70 mm		A. 747- 3	<b>7,50</b>																																							
130 x 80 mm		A. 747- 4	<b>12,00</b>																																							
	<p><b>SCHONHAMMER</b> rückschlagfrei Oberfläche Polyurethan mit Metallstiel</p> <table border="0"> <tr> <td>35 x 85 mm</td> <td>Bestell- Nr.:</td> <td>A. 8110- 3</td> <td><b>14,20</b></td> </tr> <tr> <td>45 x 100 mm</td> <td></td> <td>A. 8110- 4</td> <td><b>17,10</b></td> </tr> </table>	35 x 85 mm	Bestell- Nr.:	A. 8110- 3	<b>14,20</b>	45 x 100 mm		A. 8110- 4	<b>17,10</b>																																	
35 x 85 mm	Bestell- Nr.:	A. 8110- 3	<b>14,20</b>																																							
45 x 100 mm		A. 8110- 4	<b>17,10</b>																																							
	<p><b>FLACHMEISSEL</b> mit Gummi- Handschutz Länge 200 mm</p> <table border="0"> <tr> <td></td> <td>Bestell- Nr.:</td> <td>A. 8760</td> <td><b>9,80</b></td> </tr> </table>		Bestell- Nr.:	A. 8760	<b>9,80</b>																																					
	Bestell- Nr.:	A. 8760	<b>9,80</b>																																							
	<p><b>SPLINTENTREIBER</b> Spitze zylindrisch Länge 150 mm Durchmesser</p> <table border="0"> <tr> <td>2 mm</td> <td>Bestell- Nr.:</td> <td>A. 775- 1</td> <td><b>3,00</b></td> </tr> <tr> <td>3 mm</td> <td></td> <td>A. 775- 2</td> <td><b>3,00</b></td> </tr> <tr> <td>4 mm</td> <td></td> <td>A. 775- 3</td> <td><b>3,00</b></td> </tr> <tr> <td>5 mm</td> <td></td> <td>A. 775- 4</td> <td><b>3,00</b></td> </tr> <tr> <td>6 mm</td> <td></td> <td>A. 775- 5</td> <td><b>3,00</b></td> </tr> <tr> <td>7 mm</td> <td></td> <td>A. 775- 9</td> <td><b>3,00</b></td> </tr> <tr> <td>8 mm</td> <td></td> <td>A. 775- 6</td> <td><b>3,50</b></td> </tr> <tr> <td>10 mm</td> <td></td> <td>A. 775- 7</td> <td><b>3,50</b></td> </tr> <tr> <td>12 mm</td> <td></td> <td>A. 775- 8</td> <td><b>3,50</b></td> </tr> </table> <p><b>Satz, 6- teilig</b> 2- 3- 4- 5- 6- 8 mm im Blechkasten</p> <table border="0"> <tr> <td></td> <td>Bestell- Nr.:</td> <td>A. 778</td> <td><b>21,00</b></td> </tr> </table>	2 mm	Bestell- Nr.:	A. 775- 1	<b>3,00</b>	3 mm		A. 775- 2	<b>3,00</b>	4 mm		A. 775- 3	<b>3,00</b>	5 mm		A. 775- 4	<b>3,00</b>	6 mm		A. 775- 5	<b>3,00</b>	7 mm		A. 775- 9	<b>3,00</b>	8 mm		A. 775- 6	<b>3,50</b>	10 mm		A. 775- 7	<b>3,50</b>	12 mm		A. 775- 8	<b>3,50</b>		Bestell- Nr.:	A. 778	<b>21,00</b>	
2 mm	Bestell- Nr.:	A. 775- 1	<b>3,00</b>																																							
3 mm		A. 775- 2	<b>3,00</b>																																							
4 mm		A. 775- 3	<b>3,00</b>																																							
5 mm		A. 775- 4	<b>3,00</b>																																							
6 mm		A. 775- 5	<b>3,00</b>																																							
7 mm		A. 775- 9	<b>3,00</b>																																							
8 mm		A. 775- 6	<b>3,50</b>																																							
10 mm		A. 775- 7	<b>3,50</b>																																							
12 mm		A. 775- 8	<b>3,50</b>																																							
	Bestell- Nr.:	A. 778	<b>21,00</b>																																							
	<p><b>KÖRNER</b> achtkantig, lackiert, Spitze blank Länge 120 mm</p> <table border="0"> <tr> <td></td> <td>Bestell- Nr.:</td> <td>A. 770</td> <td><b>2,80</b></td> </tr> </table>		Bestell- Nr.:	A. 770	<b>2,80</b>																																					
	Bestell- Nr.:	A. 770	<b>2,80</b>																																							
	<p><b>AUTOMATISCHER KÖRNER</b> Federzug Länge 135 mm</p> <table border="0"> <tr> <td></td> <td>Bestell- Nr.:</td> <td>L. 200 001</td> <td><b>12,80</b></td> </tr> </table>		Bestell- Nr.:	L. 200 001	<b>12,80</b>																																					
	Bestell- Nr.:	L. 200 001	<b>12,80</b>																																							

	<p><b>DICHTUNGSSCHABER</b>  <b>Standartform</b>            Breite x Länge            22 x 280 mm</p> <p>Bestell- Nr.: A. 1485</p>	<p>Preis in € ohne MWst</p> <p><b>7,90</b></p>																														
	<p><b>MONTIEREISEN/ SCHABER</b>            universelle Anwendung            stabiler Kunststoffgriff, Sechskantschaft</p> <table border="1"> <thead> <tr> <th>Schab- breite mm</th> <th>Schaft- durchm. mm</th> <th>Schaft- länge mm</th> <th>Gesamt- länge mm</th> <th>Bestell- Nr.:</th> </tr> </thead> <tbody> <tr> <td>16</td> <td>9,9</td> <td>180</td> <td>310</td> <td>E. 10332- 07</td> </tr> <tr> <td>16</td> <td>9,5</td> <td>310</td> <td>439</td> <td>E. 10332- 12</td> </tr> <tr> <td>17</td> <td>13</td> <td>460</td> <td>635</td> <td>E. 10332- 18</td> </tr> <tr> <td>18</td> <td>13</td> <td>610</td> <td>780</td> <td>E. 10332- 24</td> </tr> <tr> <td>22</td> <td>16</td> <td>740</td> <td>915</td> <td>E. 10332- 28</td> </tr> </tbody> </table>	Schab- breite mm	Schaft- durchm. mm	Schaft- länge mm	Gesamt- länge mm	Bestell- Nr.:	16	9,9	180	310	E. 10332- 07	16	9,5	310	439	E. 10332- 12	17	13	460	635	E. 10332- 18	18	13	610	780	E. 10332- 24	22	16	740	915	E. 10332- 28	<p><b>18,20</b>  <b>20,90</b>  <b>27,50</b>  <b>31,40</b>  <b>37,90</b></p>
Schab- breite mm	Schaft- durchm. mm	Schaft- länge mm	Gesamt- länge mm	Bestell- Nr.:																												
16	9,9	180	310	E. 10332- 07																												
16	9,5	310	439	E. 10332- 12																												
17	13	460	635	E. 10332- 18																												
18	13	610	780	E. 10332- 24																												
22	16	740	915	E. 10332- 28																												
	<p><b>MONTAGEHAKEN</b>  <b>Satz, 4- teilig</b>            Sechskant- Griff aus Aluminium            gerade, 45° und 90° abgewinkelt, rund gebogen            Länge 175 mm            Hakenlänge 85 mm</p> <p>Bestell- Nr.: E. 10333</p>	<p><b>14,80</b></p>																														
	<p><b>FEDERMONTAGE- WERKZEUG</b>            zum Aus- und Einhängen von Zugfedern,            z.B. Ständer, Auspuffbefestigung, u.s.w.</p> <p>Bestell- Nr.: BUZ. 4950</p>	<p><b>10,50</b></p>																														
	<p><b>TELESKOP- MAGNETHEBER</b>            mit Taschenklip und Reinigungsnadel            Durchmesser Magnetkopf: 6 mm            Hebevermögen: ca. 500 g            Länge: 155- 580 mm</p> <p>Bestell- Nr.: KS. 550. 1001</p>	<p><b>7,50</b></p>																														
	<p><b>METALL- SÄGEBOGEN</b>            verstellbar            mit einseitigem Sägeblatt</p> <p>Bestell- Nr.: A. 1355</p> <p><b>Sägeblätter HSS</b>            einseitig            13 x 0,63 mm            Zahnung 24            Packmenge 10 Stück</p> <p>Bestell- Nr.: L. 212 010</p>	<p><b>5,90</b></p> <p><b>14,80</b></p>																														
	<p><b>SÄGEBLATTHALTER</b>            für Standartsägeblätter            Kunststoffgriff            verstellbar</p> <p>Bestell- Nr.: A. 1361</p>	<p><b>5,90</b></p>																														

	<p><b>ZYLINDERHONGERÄTE</b>            die beiden kleinen Geräte als Reinigungsgeräte für Rohre, Zylinder, Lagerschalen            die beiden grösseren Geräte als Hongeräte (Glasurbrecher) für Kompressionszylinder</p> <p>1/4"- Antriebsschaft, flexibel            zum Einspannen in Bohrmaschinen            Honarme selbstspreizend, nachspannbar            Honsegmente auswechselbar</p> <table border="1"> <thead> <tr> <th>Typ</th> <th>Zyl- mm</th> <th>Hon- arme</th> <th>Segment- länge mm</th> <th>Bestell- Nr.:</th> <th></th> </tr> </thead> <tbody> <tr> <td>1</td> <td>19- 56</td> <td>2</td> <td>28</td> <td>L. 211 001</td> <td><b>24,40</b></td> </tr> <tr> <td>2</td> <td>20- 60</td> <td>3</td> <td>28</td> <td>L. 211 002</td> <td><b>26,60</b></td> </tr> <tr> <td>3</td> <td>32- 60</td> <td>3</td> <td>50</td> <td>L. 211 003</td> <td><b>28,90</b></td> </tr> <tr> <td>4</td> <td>50- 125</td> <td>3</td> <td>75</td> <td>L. 211 004</td> <td><b>58,50</b></td> </tr> <tr> <td>5</td> <td>50- 175</td> <td>3</td> <td>100</td> <td>L. 211 005</td> <td><b>64,10</b></td> </tr> </tbody> </table>	Typ	Zyl- mm	Hon- arme	Segment- länge mm	Bestell- Nr.:		1	19- 56	2	28	L. 211 001	<b>24,40</b>	2	20- 60	3	28	L. 211 002	<b>26,60</b>	3	32- 60	3	50	L. 211 003	<b>28,90</b>	4	50- 125	3	75	L. 211 004	<b>58,50</b>	5	50- 175	3	100	L. 211 005	<b>64,10</b>	<p>Preis in € ohne MWSt</p>																																																
Typ	Zyl- mm	Hon- arme	Segment- länge mm	Bestell- Nr.:																																																																																		
1	19- 56	2	28	L. 211 001	<b>24,40</b>																																																																																	
2	20- 60	3	28	L. 211 002	<b>26,60</b>																																																																																	
3	32- 60	3	50	L. 211 003	<b>28,90</b>																																																																																	
4	50- 125	3	75	L. 211 004	<b>58,50</b>																																																																																	
5	50- 175	3	100	L. 211 005	<b>64,10</b>																																																																																	
	<p><b>ERSATZSEGMENTE</b>  <b>für Hongeräte</b>            Sätze, 2- teilig oder 3- teilig mit Splinten</p> <table border="1"> <thead> <tr> <th>für Typ</th> <th>Stück</th> <th>Länge mm</th> <th>Körnung</th> <th>Bestell- Nr.:</th> <th></th> </tr> </thead> <tbody> <tr> <td>1</td> <td>2</td> <td>28</td> <td>normal</td> <td>L. 211 101</td> <td><b>9,90</b></td> </tr> <tr> <td>1</td> <td>2</td> <td>28</td> <td>fein</td> <td>L. 211 111</td> <td><b>9,90</b></td> </tr> <tr> <td>2+3</td> <td>3</td> <td>28</td> <td>normal</td> <td>L. 211 102</td> <td><b>12,50</b></td> </tr> <tr> <td>2+3</td> <td>3</td> <td>28</td> <td>fein</td> <td>L. 211 112</td> <td><b>12,50</b></td> </tr> <tr> <td>2+3</td> <td>3</td> <td>50</td> <td>normal</td> <td>L. 211 103</td> <td><b>17,50</b></td> </tr> <tr> <td>2+3</td> <td>3</td> <td>50</td> <td>fein</td> <td>L. 211 113</td> <td><b>17,50</b></td> </tr> <tr> <td>2+3</td> <td>3</td> <td>19</td> <td>fein</td> <td>L. 211 100</td> <td><b>17,50</b></td> </tr> <tr> <td>4+5</td> <td>3</td> <td>75</td> <td>normal</td> <td>L. 211 104</td> <td><b>29,00</b></td> </tr> <tr> <td>4+5</td> <td>3</td> <td>75</td> <td>fein</td> <td>L. 211 114</td> <td><b>29,00</b></td> </tr> <tr> <td>4+5</td> <td>3</td> <td>75</td> <td>grob</td> <td>L. 211 124</td> <td><b>29,00</b></td> </tr> <tr> <td>4+5</td> <td>3</td> <td>100</td> <td>normal</td> <td>L. 211 105</td> <td><b>32,50</b></td> </tr> <tr> <td>4+5</td> <td>3</td> <td>100</td> <td>fein</td> <td>L. 211 115</td> <td><b>32,50</b></td> </tr> <tr> <td>4+5</td> <td>3</td> <td>100</td> <td>grob</td> <td>L. 211 125</td> <td><b>32,50</b></td> </tr> </tbody> </table>	für Typ	Stück	Länge mm	Körnung	Bestell- Nr.:		1	2	28	normal	L. 211 101	<b>9,90</b>	1	2	28	fein	L. 211 111	<b>9,90</b>	2+3	3	28	normal	L. 211 102	<b>12,50</b>	2+3	3	28	fein	L. 211 112	<b>12,50</b>	2+3	3	50	normal	L. 211 103	<b>17,50</b>	2+3	3	50	fein	L. 211 113	<b>17,50</b>	2+3	3	19	fein	L. 211 100	<b>17,50</b>	4+5	3	75	normal	L. 211 104	<b>29,00</b>	4+5	3	75	fein	L. 211 114	<b>29,00</b>	4+5	3	75	grob	L. 211 124	<b>29,00</b>	4+5	3	100	normal	L. 211 105	<b>32,50</b>	4+5	3	100	fein	L. 211 115	<b>32,50</b>	4+5	3	100	grob	L. 211 125	<b>32,50</b>	
für Typ	Stück	Länge mm	Körnung	Bestell- Nr.:																																																																																		
1	2	28	normal	L. 211 101	<b>9,90</b>																																																																																	
1	2	28	fein	L. 211 111	<b>9,90</b>																																																																																	
2+3	3	28	normal	L. 211 102	<b>12,50</b>																																																																																	
2+3	3	28	fein	L. 211 112	<b>12,50</b>																																																																																	
2+3	3	50	normal	L. 211 103	<b>17,50</b>																																																																																	
2+3	3	50	fein	L. 211 113	<b>17,50</b>																																																																																	
2+3	3	19	fein	L. 211 100	<b>17,50</b>																																																																																	
4+5	3	75	normal	L. 211 104	<b>29,00</b>																																																																																	
4+5	3	75	fein	L. 211 114	<b>29,00</b>																																																																																	
4+5	3	75	grob	L. 211 124	<b>29,00</b>																																																																																	
4+5	3	100	normal	L. 211 105	<b>32,50</b>																																																																																	
4+5	3	100	fein	L. 211 115	<b>32,50</b>																																																																																	
4+5	3	100	grob	L. 211 125	<b>32,50</b>																																																																																	

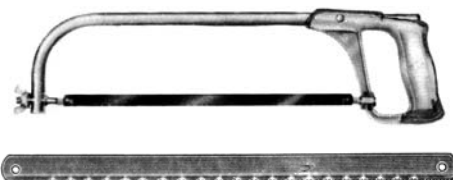
### V-COIL

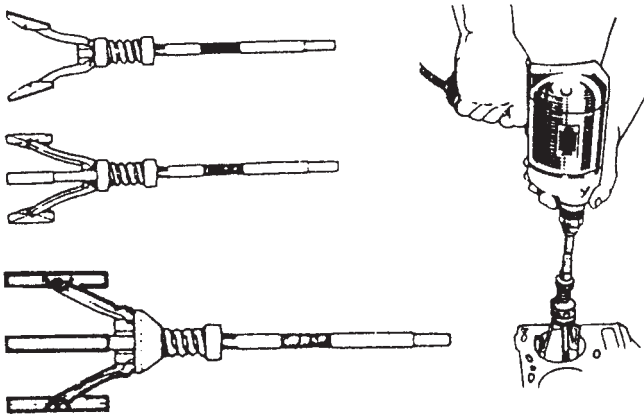
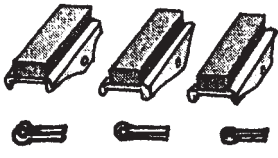
Schneiden

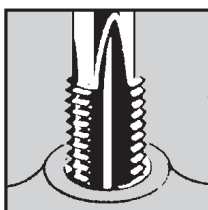

Einbau

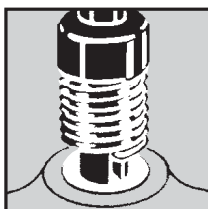

Mitnehmerzapfenentfernung

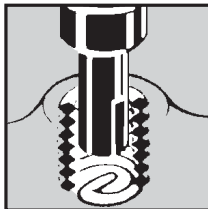

## GEWINDE- REPARATUR- SORTIMENT „V- COIL“

Preis in €  
ohne MWSt

enthält

je 1 Spezial- Gewindebohrer  
je 1 Spiralbohrer  
je 1 Hand- Einbauwerkzeug  
je 1 Zapfenbrecher  
und die angegebene Anzahl  
Gewindeeinsätze 1,5 D (Länge=1,5 x Durchmesser)

### für metrische Normalgewinde M 5 - M 12

M 5 x 0,8	25 Stück
M 6 x 1,0	25 Stück
M 8 x 1,25	25 Stück
M 10 x 1,5	25 Stück
M 12 x 1,75	10 Stück

Bestell- Nr.: VC. 04081 **145,00**

### für amerikanische Normalgewinde UNC 1/4" - 1/2"

UNC 1/4" x 20	25 Stück
UNC 5/16" x 18	25 Stück
UNC 3/8" x 16	25 Stück
UNC 7/16" x 14	10 Stück
UNC 1/2" x 13	10 Stück

Bestell- Nr.: VC. 04184 **180,00**

### für amerikanische Feingewinde UNF 1/4" - 1/2"

UNF 1/4" x 28	25 Stück
UNF 5/16" x 24	25 Stück
UNF 3/8" x 24	25 Stück
UNF 7/16" x 20	10 Stück
UNF 1/2" x 20	10 Stück

Bestell- Nr.: VC. 04185 **180,00**

### für britische Normalgewinde BSW 1/4" - 1/2"

BSW 1/4" x 20	25 Stück
BSW 5/16" x 18	25 Stück
BSW 3/8" x 16	25 Stück
BSW 7/16" x 14	10 Stück
BSW 1/2" x 12	10 Stück

Bestell- Nr.: VC. 04186 **180,00**

### für britische Feingewinde BSF 1/4" - 1/2"

BSF 1/4" x 26	25 Stück
BSF 5/16" x 22	25 Stück
BSF 3/8" x 20	25 Stück
BSF 7/16" x 18	10 Stück
BSF 1/2" x 16	10 Stück

Bestell- Nr.: VC. 04187 **180,00**

### V-COIL



## GEWINDE-REPARATUR-SATZ

enthält

je 1 Spezial- Gewindebohrer

je 1 Spiralbohrer

je 1 Hand- Einbauwerkzeug

je 1 Zapfenbrecher

und die angegebene Anzahl

Gewindeeinsätze 1,5 D (Länge=1,5 x Durchmesser)

### für metrische Normalgewinde und Feingewinde

für Gewinde

Bestell- Nr.:

M 4 x 0,7	20 Stück	VC. 04007	20,00
M 5 x 0,8	20 Stück	VC. 04009	20,80
M 6 x 1,0	20 Stück	VC.04010	22,40
M 7 x 1,0	20 Stück	VC. 04011	28,50
M 8 x 1,25	20 Stück	VC. 04012	28,50
M 8 x 1,0	20 Stück	VC. 04013	28,50
M 9 x 1,25	15 Stück	VC. 04014	31,60
M10 x 1,5	15 Stück	VC. 04016	30,50
M 10 x 1,25	15 Stück	VC. 04017	30,50
M 10 x 1,0	15 Stück	VC. 04018	30,50
M 11 x 1,5	10 Stück	VC. 04019	34,20
M 12 x 1,75	10 Stück	VC. 04021	34,20
M 12 x 1,5	10 Stück	VC. 04022	34,20
M 12 x 1,25	10 Stück	VC. 04023	34,20
M 12 x 1,0	10 Stück	VC. 04024	34,20

### M 14 - M 36 und M2 - M 3,5

### für Zündkerzengewinde

M 10 x 1,0 x 10 mm	15 Stück	VC. 04018.1	30,50
M 14 x 1,25 x 8,4 mm	5 Stück		
M 14 x 1,25 x 12,4 mm	5 Stück		
M 14 x 1,25 x 16,4 mm	5 Stück	VC. 04096	47,00

### für amerikanische Normalgewinde

UNC No. 10 x 24	20 Stück	VC. 04104	26,30
UNC No. 12 x 24	20 Stück	VC. 04105	26,30
UNC 1/4" x 20	20 Stück	VC. 04107	23,70
UNC 5/16" x 18	20 Stück	VC. 04108	29,00
UNC 3/8" x 16	15 Stück	VC. 04109	31,00
UNC 7/16" x 14	10 Stück	VC. 04110	34,80
UNC 1/2" x 13	10 Stück	VC. 04111	38,20

### für amerikanische Feingewinde

UNF No. 8 x 36	20 Stück	VC. 04122	26,30
UNF No. 10 x 32	20 Stück	VC. 04123	26,30
UNF 1/4" x 28	20 Stück	VC. 04125	23,70
UNF 5/16" x 24	20 Stück	VC. 04126	29,00
UNF 3/8" x 24	15 Stück	VC. 04127	31,00
UNF 7/16" x 20	10 Stück	VC.04128	34,80
UNF 1/2" x 20	10 Stück	VC.04129	38,20

UNC 9/16 - 1"

UNF 9/16 - 1"

auf Anfrage

### für britische Normalgewinde

BSW 3/16" x 24	20 Stück	VC. 04142	26,30
BSW 1/4" x 20	20 Stück	VC. 04143	23,70
BSW 5/16" x 18	20 Stück	VC. 04144	29,00
BSW 3/8" x 16	15 Stück	VC. 04145	31,00
BSW 7/16" x 14	10 Stück	VC. 04146	34,80
BSW 1/2" x 12	10 Stück	VC. 04147	38,20

### für britische Feingewinde

BSF 3/16" x 32	20 Stück	VC. 04162	26,30
BSF 1/4" x 26	20 Stück	VC. 04163	23,70
BSF 5/16" x 22	20 Stück	VC. 04164	29,00
BSF 3/8" x 20	15 Stück	VC. 04165	31,00
BSF 7/16" x 18	10 Stück	VC. 04166	34,80
BSF 1/2" x 16	10 Stück	VC. 04167	38,20

BSW 9/16 - 1"

BSF 9/16 - 1"

auf Anfrage

Preis in €  
ohne MwSt

<b>GEWINDEEINSÄTZE V-COIL</b> für metrisches Gewinde			Preis in € ohne MWSt		<b>GEWINDEEINSÄTZE V-COIL</b> für Zündkerzengewinde			Preis in € ohne MWSt	
Gewinde	Länge	Bestell-Nr.	10 Stück	100 Stück	Gewinde	Länge	Bestell-Nr.	10 Stück	50 Stück
M 4 x 0,7	1,0 D	VC.07207	3,00	14,00	M 14 x 1.25	8,4 mm	VC.07128	11,00	27,50
	1,5 D	VC.07307	3,00	14,00		12,4 mm	VC.07228	11,00	27,50
	2,0 D	VC.07407	3,00	14,00		16,4 mm	VC.07328	11,00	27,50
	2,5 D	VC.07507	3,50	17,00	<b>M 2 bis M 3,5 und M 14 bis M 36</b> auf Anfrage				
	3,0 D	VC.07607	4,00	20,00					
M 5 x 0,8	1,0 D	VC.07208	3,20	16,00	<b>für amerikanische Normalgewinde UNC</b>				
	1,5 D	VC.07308	3,20	16,00					
	2,0 D	VC.07408	3,60	18,00	Gewinde	Länge	Bestell-Nr.	10 Stück	100 Stück
	2,5 D	VC.07508	4,40	22,00	UNC 1/4 x 20	1,0 D	VC.08207	3,80	19,00
	3,0 D	VC.07608	5,20	26,00		1,5 D	VC.08307	3,80	19,00
M 8 x 1,0	1,0 D	VC.07209	3,80	19,00		2,0 D	VC.08407	4,60	23,00
	1,5 D	VC.07309	3,80	19,00		2,5 D	VC.08507	5,60	28,00
	2,0 D	VC.07409	4,20	21,00		3,0 D	VC.08607	6,80	34,00
	2,5 D	VC.07509	5,00	25,00	UNC 5/16 x 18	1,0 D	VC.08208	5,00	25,00
	3,0 D	VC.07609	6,20	31,00		1,5 D	VC.08308	5,00	25,00
M 7 x 1,0	1,0 D	VC.07210	3,80	19,00		2,0 D	VC.08408	6,40	32,00
	1,5 D	VC.07310	4,60	23,00		2,5 D	VC.08508	7,60	38,00
	2,0 D	VC.07410	5,00	25,00		3,0 D	VC.08608	9,20	46,00
	2,5 D	VC.07510	6,00	30,00	UNC 3/8 x 16	1,0 D	VC.08209	7,80	39,00
	3,0 D	VC.07610	7,20	36,00		1,5 D	VC.08309	7,80	39,00
M 8 x 1,25	1,0 D	VC.07211	3,80	19,00		2,0 D	VC.08409	9,60	48,00
	1,5 D	VC.07311	3,80	19,00		2,5 D	VC.08509	11,60	58,00
	2,0 D	VC.07411	5,00	25,00		3,0 D	VC.08609	13,80	69,00
	2,5 D	VC.07511	6,00	30,00	UNC 7/16 x 14	1,0 D	VC.08210	8,60	43,00
	3,0 D	VC.07611	7,20	36,00		1,5 D	VC.08310	9,60	48,00
M8 x 1,0	1,0 D	VC.07212	4,20	21,00		2,0 D	VC.08410	11,80	59,00
	1,5 D	VC.07312	4,20	21,00		2,5 D	VC.08510	14,00	70,00
	2,0 D	VC.07412	5,40	27,00		3,0 D	VC.08610	17,20	86,00
	2,5 D	VC.07512	6,40	32,00	UNC 1/2 x 13	1,0 D	VC.08211	8,60	43,00
	3,0 D	VC.07612	7,80	39,00		1,5 D	VC.08311	9,60	48,00
M 9 x 1,25	1,0 D	VC.07213	4,80	23,00		2,0 D	VC.08411	11,80	59,00
	1,5 D	VC.07313	6,80	34,00		2,5 D	VC.08511	14,00	70,00
	2,0 D	VC.07413	6,80	34,00		3,0 D	VC.08611	17,20	86,00
	2,5 D	VC.07513	7,20	36,00	<b>für amerikanische Feingewinde UNF</b>				
	3,0 D	VC.07613	8,40	42,00					
M 10 x 1,5	1,0 D	VC.07215	4,20	21,00	Gewinde	Länge	Bestell-Nr.	10 Stück	100 Stück
	1,5 D	VC.07315	5,00	25,00	UNF 1/4 x 28	1,0 D	VC.08225	3,80	19,00
	2,0 D	VC.07415	5,80	29,00		1,5 D	VC.08325	3,80	19,00
	2,5 D	VC.07515	7,20	36,00		2,0 D	VC.08425	4,60	23,00
	3,0 D	VC.07615	8,40	42,00		2,5 D	VC.08525	5,60	28,00
M 10 x 1,25	1,0 D	VC.07216	4,20	21,00		3,0 D	VC.08625	6,80	34,00
	1,5 D	VC.07316	5,00	25,00	UNF 5/16 x 24	1,0 D	VC.08226	5,00	25,00
	2,0 D	VC.07416	5,80	29,00		1,5 D	VC.08326	5,00	25,00
	2,5 D	VC.07516	7,20	36,00		2,0 D	VC.08426	6,40	32,00
	3,0 D	VC.07616	8,40	42,00		2,5 D	VC.08526	7,60	38,00
M 10 x 1,0	1,0 D	VC.07217	4,20	21,00		3,0 D	VC.08626	9,20	46,00
	1,5 D	VC.07317	5,00	25,00	UNF 3/8 x 24	1,0 D	VC.08227	7,80	39,00
	2,0 D	VC.07417	5,80	29,00		1,5 D	VC.08327	7,80	39,00
	2,5 D	VC.07517	7,20	36,00		2,0 D	VC.08427	9,60	48,00
	3,0 D	VC.07617	8,40	42,00		2,5 D	VC.08527	11,60	58,00
M 11 x 1,5	1,0 D	VC.07219	7,00	35,00		3,0 D	VC.08627	13,80	69,00
	1,5 D	VC.07319	8,80	44,00	UNF 7/16 x 20	1,0 D	VC.08228	8,60	43,00
	2,0 D	VC.07419	8,80	44,00		1,5 D	VC.08328	9,60	48,00
	2,5 D	VC.07519	10,40	52,00		2,0 D	VC.08428	11,80	59,00
	3,0 D	VC.07619	12,60	63,00		2,5 D	VC.08528	14,00	70,00
M 12 x 1,75	1,0 D	VC.07221	6,60	33,00		3,0 D	VC.08628	17,20	86,00
	1,5 D	VC.07321	7,80	39,00	UNF 1/2 x 20	1,0 D	VC.08229	8,60	43,00
	2,0 D	VC.07421	8,80	44,00		1,5 D	VC.08329	9,60	48,00
	2,5 D	VC.07521	10,40	52,00		2,0 D	VC.08429	11,80	59,00
	3,0 D	VC.07621	12,60	63,00		2,5 D	VC.08529	14,00	70,00
M 12 x 1,5	1,0 D	VC.07222	6,60	33,00		3,0 D	VC.08629	17,20	86,00
	1,5 D	VC.07322	7,80	39,00	<b>UNC + UNF No. 2 bis 12 und 9/16 bis 1"</b> für britische Normal- und Feingewinde BSW und BSF				
	2,0 D	VC.07422	8,80	44,00					
	2,5 D	VC.07522	10,40	52,00	<b>MONTAGEWERKZEUGE</b> für Gewindeeinsätze V- COIL				
	3,0 D	VC.07622	12,60	63,00					
M 12 x 1,25	1,0 D	VC.07223	6,60	33,00	Spezial- Gewindebohrer	auf Anfrage			
	1,5 D	VC.07323	7,80	39,00	Hand- und Maschinen- Einbauwerkzeuge				
	2,0 D	VC.07423	8,80	44,00	Zapfenbrecher	auf Anfrage			
	2,5 D	VC.07523	10,40	52,00	Ausdrehwerkzeuge				
	3,0 D	VC.07623	12,60	63,00					
M 12 x 1,0	1,0 D	VC.07224	6,60	33,00					
	1,5 D	VC.07324	7,80	39,00					
	2,0 D	VC.07424	8,80	44,00					
	2,5 D	VC.07524	10,40	52,00					
	3,0 D	VC.07624	12,60	63,00					



## ZÜNDKERZENGEWINDE- REPERATUR- SATZ

mit Gewindebüchsen  
fester Sitz, ausdrehfest  
besonders kompressionsdicht

enthält 1 Spezial- Gewindebohrer  
und Gewindebüchsen

M 12 x 1,25 x 12,7 mm	16 Stück
Bestell- Nr.:	E. 248

**49,50**

M 14 x 1,25 x 12,7 mm	8 Stück
M 14 x 1,25 x 19,0 mm	8 Stück
Bestell- Nr.:	E. 243

**46,00**

M 14 x 1,25 x 17,5 mm	16 Stück
für Zündkerzen mit Konusdichtsatz	
Bestell- Nr.:	A. 1145

**69,00**

## Zündkerzengewindeeinsätze

synchron verlaufendes Gewinde innen und außen  
Spezialstahl, rostgeschützt  
Packmenge 10 Stück, Preis je Packung

für Gewinde	Länge	Bestell- Nr.:	
M 12 x 1,25	12,7 mm	E. 113	<b>20,00</b>

M 14 x 1,25	9,5 mm	E. 1109	<b>12,00</b>
mit Dichtring	11,1 mm	E. 1111	<b>12,00</b>
	12,7 mm	E. 1113	<b>12,00</b>
	19,0 mm	E. 1119	<b>14,00</b>

M 14 x 1,25	11,1 mm	E. 2113	<b>16,00</b>
mit Konus	17,5 mm	E. 2119	<b>16,00</b>

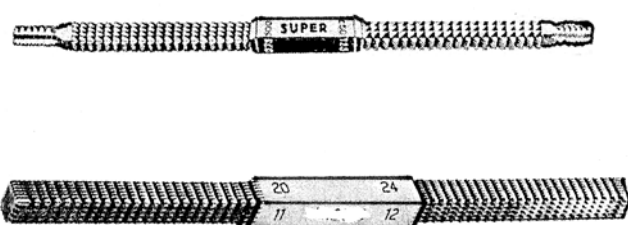
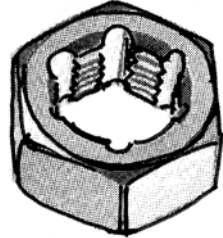
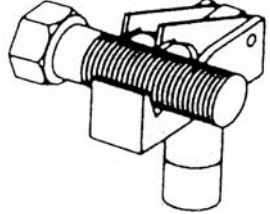
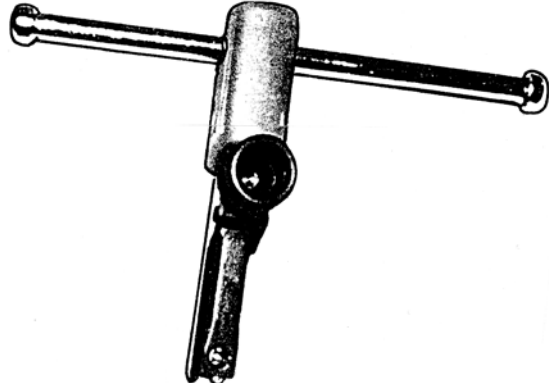
	<p><b>GEWINDEFEILE</b> metrisch für Gewinde M 5 - M 27 mit den Steigungen 0,8 - 1,0 - 1,25 - 1,5 - 1,75 - 2,0 - 2,5 - 3,0</p> <p><b>für Innen- und Außengewinde</b> Länge 230 mm Bestell- Nr.: A. 1140- 1 <b>29,90</b></p> <p><b>für Außengewinde</b> Länge 215 mm Bestell- Nr.: E. 10530 <b>19,90</b></p> <p><b>für Außengewinde UNC</b> mit den Steigungen 11 - 12 - 13 - 14 - 16 - 18 - 20 - 24 TPI Länge 205 mm Bestell- Nr.: E. 10531 <b>19,90</b></p> <p><b>für Außengewinde UNF</b> mit den Steigungen 9 - 10 - 12 - ? - 20 - 27 - 28 - 32 - TPI Länge 205 mm Bestell- Nr.: E. 10532 <b>19,90</b></p>	<p>Preis in € ohne MwSt</p>															
	<p><b>GEWINDE- NACHSCHNEIDE- MUTTERN</b> suchen sich das alte Gewinde und schneiden nicht neben dem alten ein neues Gewinde</p> <p><b>metrisch, Satz, 5- teilig</b> M 6 x 1 - M 8 x 1,25 - M 10 x 1,75 - M 12 x 1,5 M 12 x 1,75 Bestell- Nr.: E. 10520 <b>16,50</b></p> <p><b>UNC, Satz, 7- teilig</b> 1/4 x 20 - 5/16 x 18 - 3/16 x 16 - 7/16 x 14 1/2 x 13 - 9/16 x 12 - 5/8 x 11 Bestell- Nr.: E. 10521 <b>17,60</b></p> <p><b>UNF, Satz, 7- teilig</b> 1/4 x 28 - 5/16 x 24 - 3/8 x 24 - 7/16 x 20 1/2 x 20 - 9/16 x 18 - 5/8 x 18 Bestell- Nr.: E. 10522 <b>17,60</b></p>																
	<p><b>GEWINDENACHSCHNEIDER</b> <b>für Außengewinde</b> stufenlos verstellbar, für alle Steigungen auch für Zollgewinde geeignet für Links- und Rechtsgewinde</p> <table border="0"> <tr> <td>Einsatzbereich</td> <td>Bestell- Nr.:</td> <td></td> </tr> <tr> <td>M 4 - M 18</td> <td>MI. 250.010</td> <td><b>57,00</b></td> </tr> <tr> <td>M 18 - M 38</td> <td>MI. 250.020</td> <td><b>77,00</b></td> </tr> <tr> <td>M 32 - M 128</td> <td>MI. 250.030</td> <td><b>144,00</b></td> </tr> </table>	Einsatzbereich	Bestell- Nr.:		M 4 - M 18	MI. 250.010	<b>57,00</b>	M 18 - M 38	MI. 250.020	<b>77,00</b>	M 32 - M 128	MI. 250.030	<b>144,00</b>				
Einsatzbereich	Bestell- Nr.:																
M 4 - M 18	MI. 250.010	<b>57,00</b>															
M 18 - M 38	MI. 250.020	<b>77,00</b>															
M 32 - M 128	MI. 250.030	<b>144,00</b>															
	<p><b>für Innengewinde</b> einstellbare Schneide aus gehärtetem Stahl (58HRC) für metrische und Zollgewinde 60° UNC/ UNF geeignet für Links- und Rechtsgewinde</p> <table border="0"> <tr> <td>Einsatzbereich</td> <td>Bestell- Nr.:</td> <td></td> </tr> <tr> <td>12 - 16 mm</td> <td>MI. 260.022</td> <td><b>73,00</b></td> </tr> <tr> <td>16 - 20 mm</td> <td>MI. 260.023</td> <td><b>80,00</b></td> </tr> <tr> <td>22 - 32 mm</td> <td>MI. 260.024</td> <td><b>106,00</b></td> </tr> <tr> <td>32 - 54 mm</td> <td>MI. 260.025</td> <td><b>138,00</b></td> </tr> </table>	Einsatzbereich	Bestell- Nr.:		12 - 16 mm	MI. 260.022	<b>73,00</b>	16 - 20 mm	MI. 260.023	<b>80,00</b>	22 - 32 mm	MI. 260.024	<b>106,00</b>	32 - 54 mm	MI. 260.025	<b>138,00</b>	
Einsatzbereich	Bestell- Nr.:																
12 - 16 mm	MI. 260.022	<b>73,00</b>															
16 - 20 mm	MI. 260.023	<b>80,00</b>															
22 - 32 mm	MI. 260.024	<b>106,00</b>															
32 - 54 mm	MI. 260.025	<b>138,00</b>															
	<p><b>Ersatzschneiden 60° Austauschschneiden 55° (BSW/BSF)</b> für Innen- oder Außengewinde</p>	<p><b>auf Anfrage</b></p>															

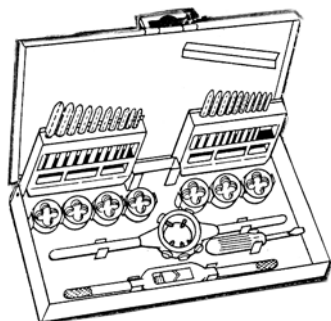

### GEWINDESCHNEID- WERKZEUG-SATZ

HSS-G 31- teilig  
für Gewindedurchmesser  
M 3 - 4 - 5 - 6 - 8 - 10 - 12

je 1 Satz Gewindebohrer 3- teilig  
je 1 St Schneideisen, Durchmesser 25 mm

1 Schneideisenhalter 25 X 9 mm  
1 Windeisen Nr. 1-1/2  
1 Schraubendreher

in Blechkassette  
Bestell-Nr.:

VK. 49 501

Preis in €  
ohne MWst

**98,00**





### DIN - GEWINDEWERKZEUG

Gewindebohrer und Schneideisen



M 1 bis M 68  
Mf 3 bis Mf 52  
BSW 1/16 bis BSW 3/2"  
BSF 3/16 bis BSF 1"  
UNC No.1 bis UNC 2"  
UNF No.0 bis UNF 1.1/2"  
G 1/6 bis G 4"  
Stahlpanzerrohr (PG)  
Trapezgewinde Tr 10 bis Tr 12  
Linksgewinde M 3L bis M 30L  
Linksgewinde Mf 6L bis Mf 24L  
Linksgewinde G 1/8"L bis G 1"L (BSP)



Sechskant- Schneideisen  
Knarren- Werkzeughalter  
verstellbare Windeisen  
Schneideisenhalter  
Gewindebohrer- Verlängerungen

**auf Anfrage**

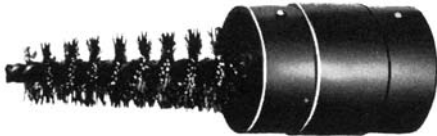

	<b>WERKSTATTFEILE</b> Ausführung nach DIN, ohne Heft Hieb 1 = bastard Hieb 2 = halbschlicht Hieb 3 = schlicht				Preis in € ohne MwSt
	Form Hieb	Länge mm	Arbeits- fläche mm	Bestell- Nr.:	
	flach- stumpf	150	16 x 4	A. 1820H1- 1	<b>4,30</b>
		200	20 x 5	A. 1820H1- 2	<b>5,20</b>
	Hieb 1	250	25 x 6,3	A. 1820H1- 3	<b>7,20</b>
		300	30,1 x 7,5	A. 1820H1- 4	<b>9,30</b>
	flach- stumpf	150	16 x 4	A. 1820H2- 1	<b>4,50</b>
		200	20 x 5	A. 1820H2- 2	<b>5,50</b>
	Hieb 2	250	25 x 6,3	A. 1820H2- 3	<b>7,50</b>
		300	30,1 x 7,5	A. 1820H2- 4	<b>9,90</b>
	flach- stumpf	150	16 x 4	A. 1820H3- 1	<b>4,70</b>
		200	20 x 5	A. 1820H3- 2	<b>5,90</b>
	Hieb 3	250	25 x 6,3	A. 1820H3- 3	<b>8,40</b>
		300	30,1 x 7,5	A. 1820H3- 4	<b>10,80</b>
	drei- kant	150	10	A. 1822H1- 1	<b>5,50</b>
		200	14	A. 1822H1- 2	<b>6,60</b>
	Hieb 1	250	17	A. 1822H1- 3	<b>9,60</b>
		300	20	A. 1822H1- 4	<b>13,90</b>
	drei- kant	150	10	A. 1822H2- 1	<b>5,70</b>
		200	14	A. 1822H2- 2	<b>6,90</b>
	Hieb 2	250	17	A. 1822H2- 3	<b>10,20</b>
		300	20	A. 1822H2- 4	<b>14,50</b>
	drei- kant	150	10	A. 1822H3- 1	<b>6,00</b>
		200	14	A. 1822H3- 2	<b>7,50</b>
	Hieb 3	250	17	A. 1822H3- 3	<b>11,20</b>
		300	20	A. 1822H3- 4	<b>14,90</b>
	vier- kant	150	6,3	A. 1823H1- 1	<b>4,60</b>
		200	8	A. 1823H1- 2	<b>5,50</b>
	Hieb 1	250	10	A. 1823H1- 3	<b>7,20</b>
		300	12,5	A. 1823H1- 4	<b>10,50</b>
	vier- kant	150	6,3	A. 1823H2- 1	<b>4,90</b>
		200	8	A. 1823H2- 2	<b>5,80</b>
	Hieb 2	250	10	A. 1823H2- 3	<b>7,70</b>
		300	12,5	A. 1823H2- 4	<b>11,10</b>
	vier- kant	150	6,3	A. 1823H3- 1	<b>5,40</b>
		200	8	A. 1823H3- 2	<b>6,80</b>
	Hieb 3	250	10	A. 1823H3- 3	<b>8,20</b>
		300	12,5	A. 1823H3- 4	<b>11,70</b>
	rund	150	6,3	A. 1824H1- 1	<b>4,20</b>
	Hieb 1	200	8	A. 1824H1- 2	<b>4,80</b>
		250	10	A. 1824H1- 3	<b>7,00</b>
		300	12,5	A. 1824H1- 4	<b>8,80</b>
	rund	150	6,3	A. 1824H2- 1	<b>4,50</b>
	Hieb 2	200	8	A. 1824H2- 2	<b>5,30</b>
		250	10	A. 1824H2- 3	<b>7,40</b>
		300	12,5	A. 1824H2- 4	<b>9,40</b>
	rund	150	6,3	A. 1824H3- 1	<b>4,80</b>
	Hieb 3	200	8	A. 1824H3- 2	<b>5,50</b>
		250	10	A. 1824H3- 3	<b>8,30</b>
		300	12,5	A. 1824H3- 4	<b>10,20</b>
	halb- rund	150	16 x 5,3	A. 1826H1- 1	<b>7,30</b>
		200	20 x 6,7	A. 1826H1- 2	<b>8,40</b>
	Hieb 1	250	25 x 8,5	A. 1826H1- 3	<b>11,40</b>
		300	31,5 x 10,6	A. 1826H1- 4	<b>14,70</b>
	halb- rund	150	16 x 5,3	A. 1826H2- 1	<b>7,30</b>
		200	20 x 6,7	A. 1826H2- 2	<b>8,90</b>
	Hieb 2	250	25 x 8,5	A. 1826H2- 3	<b>11,90</b>
		300	31,5 x 10,6	A. 1826H2- 4	<b>15,40</b>
	halb- rund	150	16 x 5,3	A. 1826H3- 1	<b>7,70</b>
		200	20 x 6,7	A. 1826H3- 2	<b>9,20</b>
	Hieb 3	250	25 x 8,5	A. 1826H3- 3	<b>12,40</b>
		300	31,5 x 10,6	A. 1826H3- 4	<b>16,20</b>

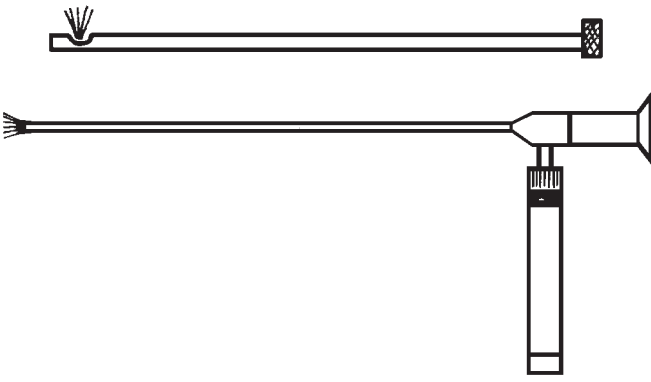
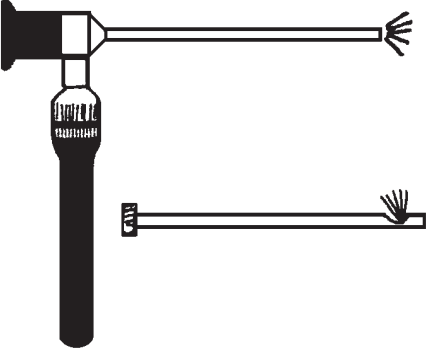

	<p><b>STAHLDRAHTBÜRSTE</b> glatter, gehärteter Gußstahl 0,31 mm Länge 280 mm</p> <table border="0"> <tr> <td>Reihen</td> <td>Bestell- Nr.:</td> <td></td> </tr> <tr> <td>1</td> <td>A. 945- 1</td> <td><b>1,30</b></td> </tr> <tr> <td>2</td> <td>A. 945- 2</td> <td><b>1,30</b></td> </tr> <tr> <td>3</td> <td>A. 945- 3</td> <td><b>1,50</b></td> </tr> <tr> <td>4</td> <td>A. 945- 4</td> <td><b>1,70</b></td> </tr> <tr> <td>5</td> <td>A. 945- 5</td> <td><b>2,00</b></td> </tr> <tr> <td>6</td> <td>A. 945- 6</td> <td><b>2,30</b></td> </tr> </table>	Reihen	Bestell- Nr.:		1	A. 945- 1	<b>1,30</b>	2	A. 945- 2	<b>1,30</b>	3	A. 945- 3	<b>1,50</b>	4	A. 945- 4	<b>1,70</b>	5	A. 945- 5	<b>2,00</b>	6	A. 945- 6	<b>2,30</b>	<p>Preis in € ohne MWst</p>
Reihen	Bestell- Nr.:																						
1	A. 945- 1	<b>1,30</b>																					
2	A. 945- 2	<b>1,30</b>																					
3	A. 945- 3	<b>1,50</b>																					
4	A. 945- 4	<b>1,70</b>																					
5	A. 945- 5	<b>2,00</b>																					
6	A. 945- 6	<b>2,30</b>																					
	<p><b>MESSINGDRAHTBÜRSTE</b> gewellter Messingdraht 0,25 mm</p> <table border="0"> <tr> <td>Reihen</td> <td>Bestell- Nr.:</td> <td></td> </tr> <tr> <td>3</td> <td>A.946- 3</td> <td><b>3,50</b></td> </tr> <tr> <td>4</td> <td>A.946- 4</td> <td><b>4,10</b></td> </tr> </table>	Reihen	Bestell- Nr.:		3	A.946- 3	<b>3,50</b>	4	A.946- 4	<b>4,10</b>													
Reihen	Bestell- Nr.:																						
3	A.946- 3	<b>3,50</b>																					
4	A.946- 4	<b>4,10</b>																					
	<p><b>ZÜNDKERZENBÜRSTE</b> gewellter Messingdraht 3- reihig, Länge 145 mm, Besatz 40 mm</p> <table border="0"> <tr> <td>Bestell- Nr.:</td> <td>A. 949</td> <td><b>1,20</b></td> </tr> </table>	Bestell- Nr.:	A. 949	<b>1,20</b>																			
Bestell- Nr.:	A. 949	<b>1,20</b>																					
	<p><b>POLKLEMMENBÜRSTE</b> Rundbürste, 2- seitig für innen und außen</p> <table border="0"> <tr> <td>Bestell- Nr.:</td> <td>A. 950</td> <td><b>7,20</b></td> </tr> </table>	Bestell- Nr.:	A. 950	<b>7,20</b>																			
Bestell- Nr.:	A. 950	<b>7,20</b>																					
 <p>agressiv      polieren      nachschärfen</p>	<p><b>PUTZBÜRSTE</b> <b>Stahldraht, gekrallt</b> mit auswechselbarem Bürstenband zum Entrosten und Entfernen von Unterboden- schutz, Dichtmasse, Dröhnschutz, u.s.w. umgekehrte Montage des Bürstenbands zum Polieren und zum Nachschärfen der Krallen</p> <p>maximale Drehzahl 4000 U/min für alle Bohrmaschinen Aufnahmedorn 9 mm Sechskant</p> <table border="0"> <tr> <td>1 Aufnahme mit 1 Bürste</td> <td>Bestell- Nr.:</td> <td></td> </tr> <tr> <td>Breite</td> <td>L. 220.023</td> <td><b>24,50</b></td> </tr> <tr> <td>23 mm</td> <td>L. 220.038</td> <td><b>29,90</b></td> </tr> <tr> <td>38 mm</td> <td></td> <td></td> </tr> <tr> <td>Ersatz- Bürstenband</td> <td></td> <td></td> </tr> <tr> <td>23 mm</td> <td>L. 220.123</td> <td><b>17,80</b></td> </tr> <tr> <td>38 mm</td> <td>L. 220.138</td> <td><b>19,80</b></td> </tr> </table>	1 Aufnahme mit 1 Bürste	Bestell- Nr.:		Breite	L. 220.023	<b>24,50</b>	23 mm	L. 220.038	<b>29,90</b>	38 mm			Ersatz- Bürstenband			23 mm	L. 220.123	<b>17,80</b>	38 mm	L. 220.138	<b>19,80</b>	
1 Aufnahme mit 1 Bürste	Bestell- Nr.:																						
Breite	L. 220.023	<b>24,50</b>																					
23 mm	L. 220.038	<b>29,90</b>																					
38 mm																							
Ersatz- Bürstenband																							
23 mm	L. 220.123	<b>17,80</b>																					
38 mm	L. 220.138	<b>19,80</b>																					

	<p><b>TECHNIKENDOSKOP</b>  hochwertiges optisches Gerät  Kunststofffaser, Lichtleitsystem  mit höchster Lichtübertragungsqualität  brillante Auflösung ab wenigen mm Objektstand  bis unendlich mit Fix- Focus- System  7,2 mm Aussendurchmesser bei 0°  Blickrichtung 254 mm Nutzlänge  8 mm Aussendurchmesser mit aufgestecktem  drehbarem Spiegelrohr mit 100° Blickrichtung  Beleuchtung erfolgt über Batteriehandgriff  mit Halogenhöchstleistungsleuchte  Ausführung in V2A  im Schutzkoffer</p> <p>Bestell- Nr.: L 232 LCE</p>	<p>Preis in € ohne MWSt</p> <p><b>485,00</b></p>
	<p><b>TECHNIKENDOSKOP</b>  Typ ECO  Nutzlänge 178 mm  Blickrichtung 0° Durchmesser 4,2 mm  Spiegelrohr mit 90° Blickrichtung  360° drehbar Durchmesser 4,8 mm  mit Batteriehandgriff  im Schutzkoffer</p> <p>Bestell- Nr.: L 232 ECO- Set</p>	<p><b>455,00</b></p>
	<p><b>TECHNIKENDOSKOP</b>  Typ Heine  gerades Endoskop  Durchmesser 8 mm  Nutzlänge 230 m  mit 12 V Halogenlampe und Ersatzbirne</p> <p>Winkelansatz 60°  Schenkellänge 120 mm</p> <p>Verbindungskabel zum Anschluß an Zigarettenanzünder</p> <p>komplett im Koffer</p> <p>Bestell- Nr.: HE.T- 532.50.246 <b>929,00</b></p> <p>wie HE.T- 532.50.246, ohne Winkelansatz  Bestell- Nr.: HE.T- 533.50.246 <b>720,00</b></p> <p>wie HE.T- 532.50.246, jedoch 6 mm Durchmesser  Bestell- Nr.: HE.T- 542.50.246 <b>1173,00</b></p> <p>wie HE.T- 542.50.246, ohne Winkelansatz  Bestell- Nr.: HE.T- 543.50.246 <b>909,80</b></p> <p>Durchmesser 6 mm, Nutzlänge 320 mm  Bestell- Nr.: HE.T- 544.50.246 <b>1224,70</b></p> <p>wie HE.T- 544.50.246, ohne Winkelansatz  Bestell- Nr.: HE.T- 545.50.246 <b>961,50</b></p> <p><b>Zubehör</b>  Winkelansatz 60°  Schenkellänge 120 mm  Bestell- Nr.: HE.T- 00.26.090 <b>254,00</b></p> <p>Winkelansatz 60°  Schenkellänge 360 mm  Bestell- Nr.: HE.T- 00.26.093 <b>455,00</b></p> <p>Ersatzbirne 12 V  Bestell- Nr.: HE.T- 05.88.079 <b>21,00</b></p>	

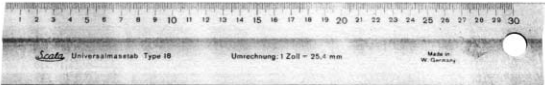
	<p><b>MESSSCHIEBER</b> Ausführung mini rostfrei, matt Messbereich bis 70 mm Bestell- Nr.: SM 216 305</p> <p>Messbereich bis 100 mm Rostgeschützt, matt 1/20 mm Bestell- Nr.: SM 216 302</p> <p>Messbereich bis 150 mm 1/20 + 1/128" Bestell- Nr.: SM 253 305</p>	<p>Preis in € ohne MWSt</p> <p><b>18,50</b></p> <p><b>14,00</b></p> <p><b>13,50</b></p>
	<p><b>UHR MESSSCHIEBER</b> Messbereich bis 150 mm 0,01</p> <p>Bestell- Nr.: Sm 217 211</p>	<p><b>34,00</b></p>
	<p><b>DIGITAL MESSSCHIEBER</b> Messbereich 150 mm mit Ein- und Ausschalter extra großes Display Bestell- Nr.: SM 230 207</p> <p>Tiefenmessbrücke für SM 230 207 Bestell- Nr.: SM 230 225</p>	<p><b>44,00</b></p> <p><b>42,00</b></p>
	<p><b>PRÄZISIONS BÜGELMESSSCHRAUBE</b> mattverchromt, Messfläche Hartmetallbestückt, Ableseung 1/100, im Holzkasten</p> <p>Messbereich 0 - 25 25 - 50 50 - 75 75 - 100 100 - 125 125 - 150</p> <p>Bestell- Nr.: SM 533 501 SM 533 502 SM 533 503 SM 533 504 SM 533 505 SM 533 506</p> <p><b>4- teiliger Satz</b>, wie oben, 0 - 100 mm Bestell- Nr.: SM 533 560</p> <p><b>MESSSCHRAUBENHALTER</b> passend für 533 501 bis 533 505 Bestell- Nr.: SM 592 101</p>	<p><b>16,50</b></p> <p><b>19,50</b></p> <p><b>23,50</b></p> <p><b>25,00</b></p> <p><b>33,00</b></p> <p><b>36,50</b></p> <p><b>89,00</b></p> <p><b>29,00</b></p>
	<p><b>ZWEIPUNKT- INNEN- MESSSCHRAUBE</b> Ablese Teile verchromt, 0,01 mm, im Holzkasten</p> <p>Messbereich 5 - 30 25 - 50 50 - 75 75 - 100</p> <p>Bestell- Nr.: SM 542 501 SM 542 502 SM 542 503 SM 542 504</p> <p><b>4- teiliger Satz</b>, 5 - 100 mm SM 542 550</p>	<p><b>63,40</b></p> <p><b>69,80</b></p> <p><b>81,30</b></p> <p><b>89,50</b></p> <p><b>298,00</b></p>

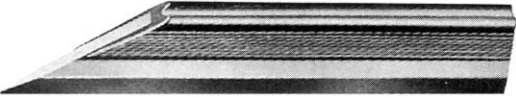
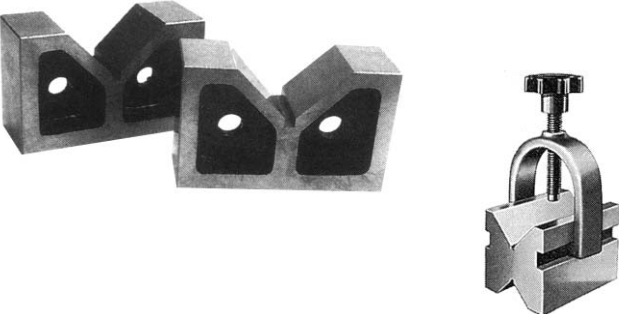
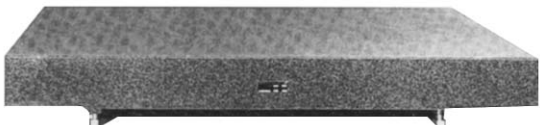
	<p><b>INNEN- FEINMESSGERÄT</b> Gestänge verchromt, gehärtete Messkugel im Holzkasten, incl. Messuhr</p> <table border="0"> <tr> <td>Messbereich (mm)</td> <td>Bestell- Nr.:</td> <td></td> </tr> <tr> <td>10 - 18</td> <td>SM 439 132</td> <td><b>103,00</b></td> </tr> <tr> <td>18 - 35</td> <td>SM 439 133</td> <td><b>103,00</b></td> </tr> <tr> <td>35 - 50</td> <td>SM 439 134</td> <td><b>99,00</b></td> </tr> <tr> <td>50 - 160</td> <td>SM 439 136</td> <td><b>103,00</b></td> </tr> <tr> <td>20 - 200</td> <td>SM 439 140</td> <td><b>189,00</b></td> </tr> </table>	Messbereich (mm)	Bestell- Nr.:		10 - 18	SM 439 132	<b>103,00</b>	18 - 35	SM 439 133	<b>103,00</b>	35 - 50	SM 439 134	<b>99,00</b>	50 - 160	SM 439 136	<b>103,00</b>	20 - 200	SM 439 140	<b>189,00</b>	<p>Preis in € ohne MwSt</p>
Messbereich (mm)	Bestell- Nr.:																			
10 - 18	SM 439 132	<b>103,00</b>																		
18 - 35	SM 439 133	<b>103,00</b>																		
35 - 50	SM 439 134	<b>99,00</b>																		
50 - 160	SM 439 136	<b>103,00</b>																		
20 - 200	SM 439 140	<b>189,00</b>																		
	<p><b>MESSUHR</b> Durchmesser 40 mm, Messbereich 0 - 8 mm Bestell- Nr.: SM 620 508 <b>24,90</b></p> <p>Durchmesser 58 mm, Messbereich 0 - 10 mm Bestell- Nr.: SM 621 110 <b>19,90</b></p> <p>Durchmesser 58 mm, Digital Bestell- Nr.: SM 622 110 <b>104,50</b></p>																			
	<p><b>ALU MASSSTAB</b> aus hochwertigem Alu gezogen 5 x 50 mm</p> <table border="0"> <tr> <td>Länge</td> <td>Bestell- Nr.:</td> <td></td> </tr> <tr> <td>300 mm</td> <td>SM 418 315</td> <td><b>9,30</b></td> </tr> <tr> <td>600 mm</td> <td>SM 418 316</td> <td><b>14,20</b></td> </tr> </table>	Länge	Bestell- Nr.:		300 mm	SM 418 315	<b>9,30</b>	600 mm	SM 418 316	<b>14,20</b>										
Länge	Bestell- Nr.:																			
300 mm	SM 418 315	<b>9,30</b>																		
600 mm	SM 418 316	<b>14,20</b>																		
	<p><b>STAHL-LINEAL</b> verchromter Blankstahl mit Fase 5 x 40 mm</p> <table border="0"> <tr> <td>Länge</td> <td>Bestell- Nr.:</td> <td></td> </tr> <tr> <td>300 mm</td> <td>SM 421 107</td> <td><b>11,50</b></td> </tr> <tr> <td>500 mm</td> <td>SM 421 109</td> <td><b>15,50</b></td> </tr> </table>	Länge	Bestell- Nr.:		300 mm	SM 421 107	<b>11,50</b>	500 mm	SM 421 109	<b>15,50</b>										
Länge	Bestell- Nr.:																			
300 mm	SM 421 107	<b>11,50</b>																		
500 mm	SM 421 109	<b>15,50</b>																		
	<p><b>PRÄZISIONS HAARLINEAL</b> Haarmesskanten gehärtet, geschliffen und geläpft mit Handwärmeschutz</p> <table border="0"> <tr> <td>Länge</td> <td>Bestell- Nr.:</td> <td></td> </tr> <tr> <td>300 mm</td> <td>SM 423 107</td> <td><b>38,50</b></td> </tr> <tr> <td>400 mm</td> <td>SM 423 108</td> <td><b>64,00</b></td> </tr> <tr> <td>500 mm</td> <td>SM 423 109</td> <td><b>91,00</b></td> </tr> </table>	Länge	Bestell- Nr.:		300 mm	SM 423 107	<b>38,50</b>	400 mm	SM 423 108	<b>64,00</b>	500 mm	SM 423 109	<b>91,00</b>							
Länge	Bestell- Nr.:																			
300 mm	SM 423 107	<b>38,50</b>																		
400 mm	SM 423 108	<b>64,00</b>																		
500 mm	SM 423 109	<b>91,00</b>																		
	<p><b>PRISMENPAAR</b> aus gehärtetem Stahlguß, Lieferung in geschliffenen und nummerierten Paaren Abmessungen Einschnitt 100 x 65 x 41 50 mm Bestell- Nr.: SM 687 103 <b>48,00</b></p> <p><b>PRISMENPAARE MIT SPANNBÜGEL</b> gehärtet und allseitig geschliffen</p> <table border="0"> <tr> <td>Abmessung</td> <td>Spannbereich</td> <td>Bestell- Nr.:</td> <td></td> </tr> <tr> <td>40 x 32 x 32</td> <td>bis 25 mm</td> <td>SM 682 101</td> <td><b>32,00</b></td> </tr> <tr> <td>75 x 55 x 55</td> <td>bis 50 mm</td> <td>SM 682 102</td> <td><b>75,00</b></td> </tr> </table>	Abmessung	Spannbereich	Bestell- Nr.:		40 x 32 x 32	bis 25 mm	SM 682 101	<b>32,00</b>	75 x 55 x 55	bis 50 mm	SM 682 102	<b>75,00</b>							
Abmessung	Spannbereich	Bestell- Nr.:																		
40 x 32 x 32	bis 25 mm	SM 682 101	<b>32,00</b>																	
75 x 55 x 55	bis 50 mm	SM 682 102	<b>75,00</b>																	
	<p><b>MESS- UND PRÜFPLATTE</b> Granitplatte nach DIN 876/ 00 bearbeitet 400 x 250 x 50 mm Bestell- Nr.: SM 681 103 <b>180,00 + Fracht</b></p>																			